

DATA SHEET FOR bio-m[®] MAGNETIC AGITATOR TYPE BMR 75

TYPICALLY USED FOR:

Waterlike liquids up to a viscosity of 250 mPas (above please speak to zeta)
Homogenization, improving of heat transfer, dissolution of solids
(other tasks please speak to zeta)
Depending on the task, for vessel contents between 50 l and 250 l

TECHNICAL DATA OF THE AGITATOR

DRIVE SYSTEM:

Worm geared motor, with 3 PLC, for operation under frequency control (not included)
3 x 230/400 V, 50 Hz, IP 55, Iso F, not Ex-proof
Motor power: 0,18 kW
Speed at 50 Hz: 560 rpm VFD speed range: 90 - 900 rpm

MAGNETIC COUPLING:

The torque is transmitted through the hermetically sealed containment shell by means of permanent magnets. The agitator head runs on ceramic bushes made from SiC vs ZrO₂. The open design and the big gap between containment shell and agitator head make sure that CIP cleaning is perfect (Qualification documents available)

DIMENSIONS:

Magnetic impeller, \varnothing d2:	100 mm
Weld plate \varnothing a1:	80 mm
Height H approx.:	200 mm
incl. Intermediate flange	(70 mm)
Length L approx. :	220 mm

M O C, PRODUCT WETTED:

1.4435, ground to Ra < 0,8 μ m, e-polished
O-Rings: EPDM, FDA-conforming

FURTHER REMARKS:

Painting, to zeta standard: RAL 5015 blue
Weight approx.: 15 kg

OPTIONS:

- speed sensor (signal processing by others)
- explosion proof design (ATEX)
- without intermediate flange
- different impeller types
- vertical drive system
(6-pole motor instead of worm geared motor)

PRINCIPLE DRAWING *

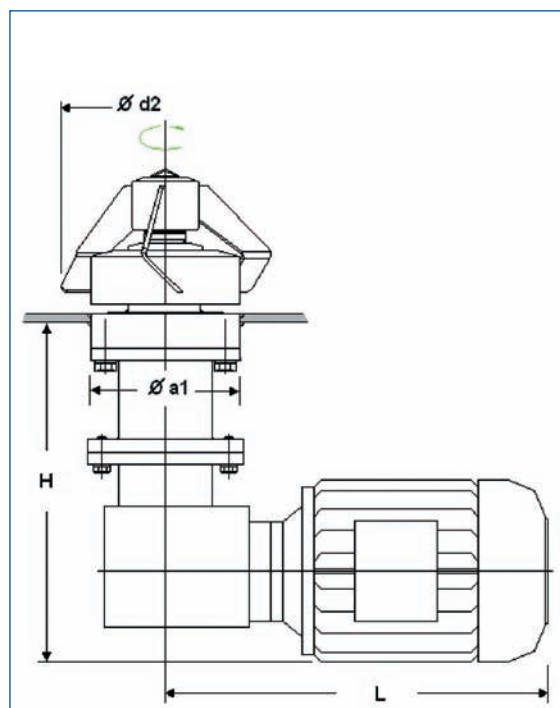

*) CAD as dwg- or dxf-file available (in case of purchase order)

